

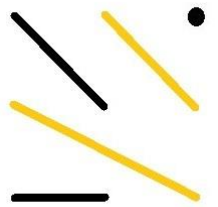

Bluetooth PN Generator
Peripheral

Product Offering



What is Bluetooth?

Bluetooth is a wireless technology standard for exchanging data over short distances from fixed and mobile devices and for building personal area networks.

Product Offering

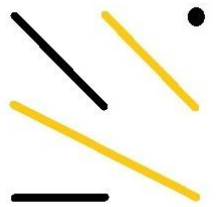

Who uses Bluetooth?

Ericsson

Intel

Lenovo

Microsoft

Motorola

Nokia





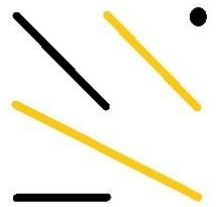









Toshiba

Product Offering



Who uses Bluetooth?

Bluetooth Product Directory

	Audio and Visual (27866)		Medical (721)
	Automotive (2090)		Phone (2387)
	Gaming (1046)		Mobile Phone Accessory (12105)
	Handheld (1907)		Office Equipment (860)
	Headset (3722)		Personal Computer (2603)
	Home Environment (5323)		Unique Products (5129)
	Input Devices (3487)		All Products (50920)

Product Offering

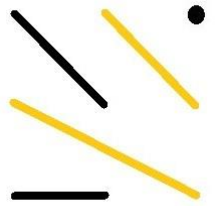

- Aurelii Comunciations Bluetooth PN Peripheral

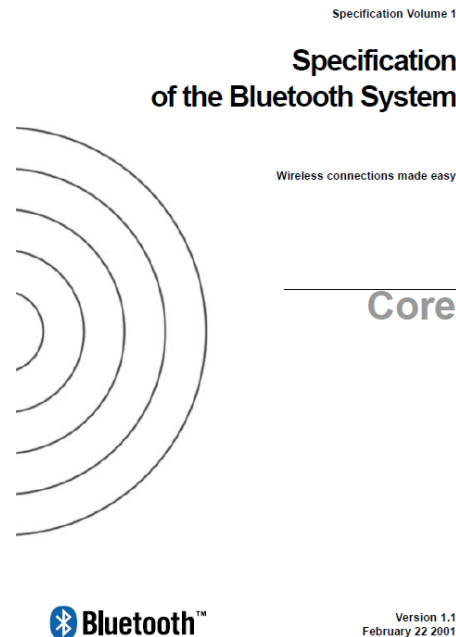

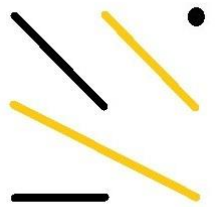

Product Offering

- Aurelii Communications Bluetooth PN Peripheral

13.2.2 Pseudo-random noise sequence generation

To generate the pseudo-random noise sequence we use the primitive polynomial $\kappa(D) = 1 + D + D^3 + D^4 + D^6$. The LFSR and its starting state are shown in Figure 13.3 on page 146. The PN sequence generated (including the extra terminating zero) becomes (hexadecimal notation) 83848D96BBCC54FC. The LFSR output starts with the left-most bit of this PN sequence. This corresponds to $p(D)$ of the previous section. Thus, using the reciprocal $p(D)$ as overlay gives the 64 bit sequence

$$p = 3F2A33DD69B121C1, \quad (\text{EQ 23})$$

1. $x(D) \bmod y(D)$ denotes the rest when $x(D)$ is divided by $y(D)$.

Product Offering

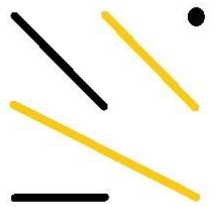

- Aurelii Communications Bluetooth PN Peripheral

BLUETOOTH SPECIFICATION Version 1.1

page 148 of 1084

Baseband Specification



where the left-most bit is p_{63} (there are two initial zeros in the binary representation of the hexadecimal digit 3), and $p_{63} = 1$ is the right-most bit.

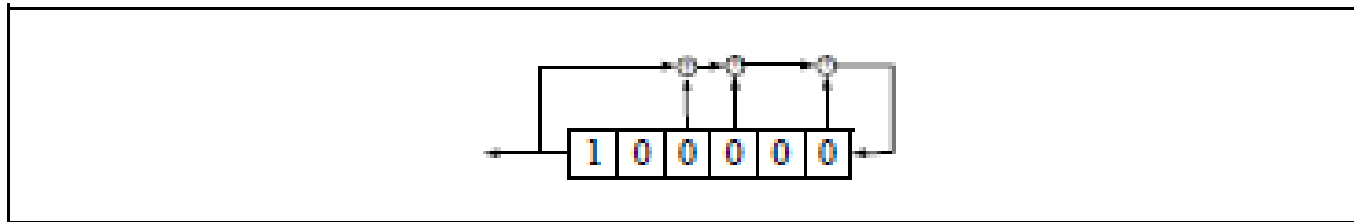
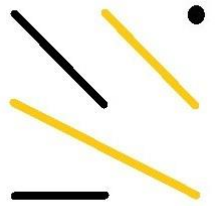
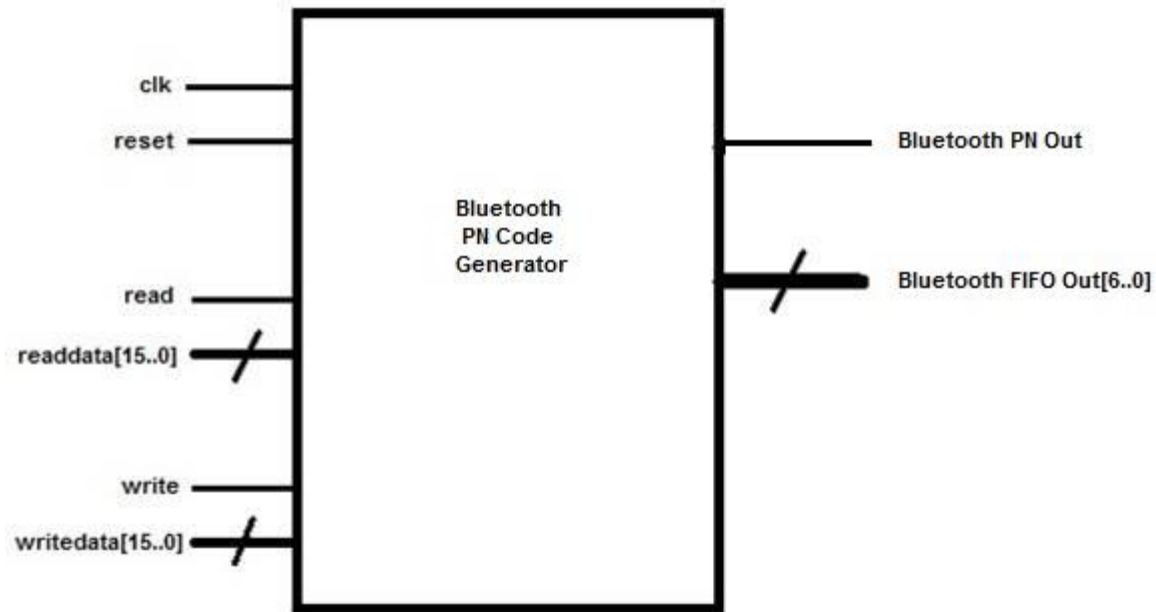

Figure 13.3: LFSR and the starting state to generate $p'(D)$

Product Offering



- Aurelii Communications Bluetooth PN Peripheral



Bluetooth PN Code Generator Block Diagram

Product Offering

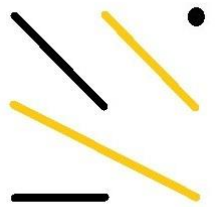

Bluetooth Code Generator Peripheral Features

- 6 bit Fibonacci Linear Feedback Shift Register
- Fixed 6 bit Register Contents for Pseudorandom (PN) Sequence
- Single Channel Serial Bluetooth Code Output
- Global Output Enable for Bluetooth Code Channel
- Local Output Enable for Bluetooth Code Channel
- Global Enable for Bluetooth Code Channel
- Local Enable for Bluetooth Code Channel

Product Offering

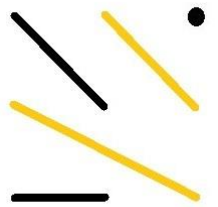

Bluetooth Code Generator Peripheral Features

- 5 bit Address and 16 bit Microprocessor Interface
 - 4 bit Control and Status Register
 - » Local Enable
 - » Local Output Enable
 - 5 bit Bluetooth PN Readback
 - Global Enable
 - Global Output Enable

Product Offering

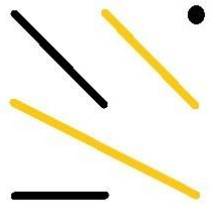

Bluetooth Code Generator Peripheral Features

- 7 bit Output for FIFO Interface
 - 6 bit PN Sequence 0 Registers
 - 1 bit Gold Code Output

Product Implementation

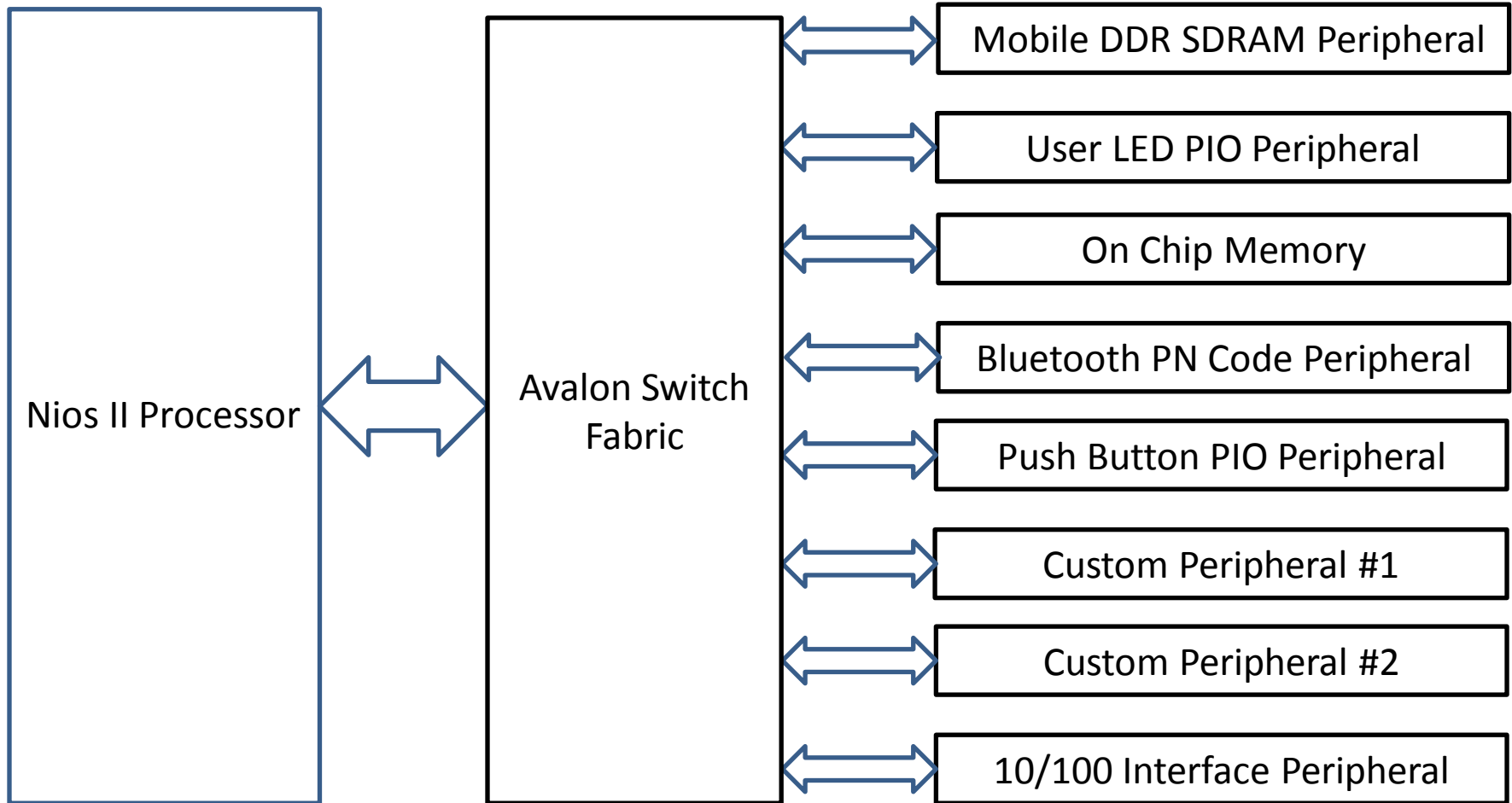
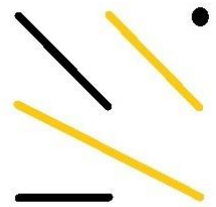

Example Bluetooth PN Code Peripheral System

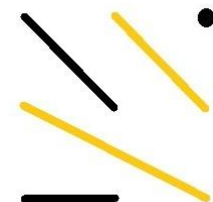

Product Implementation

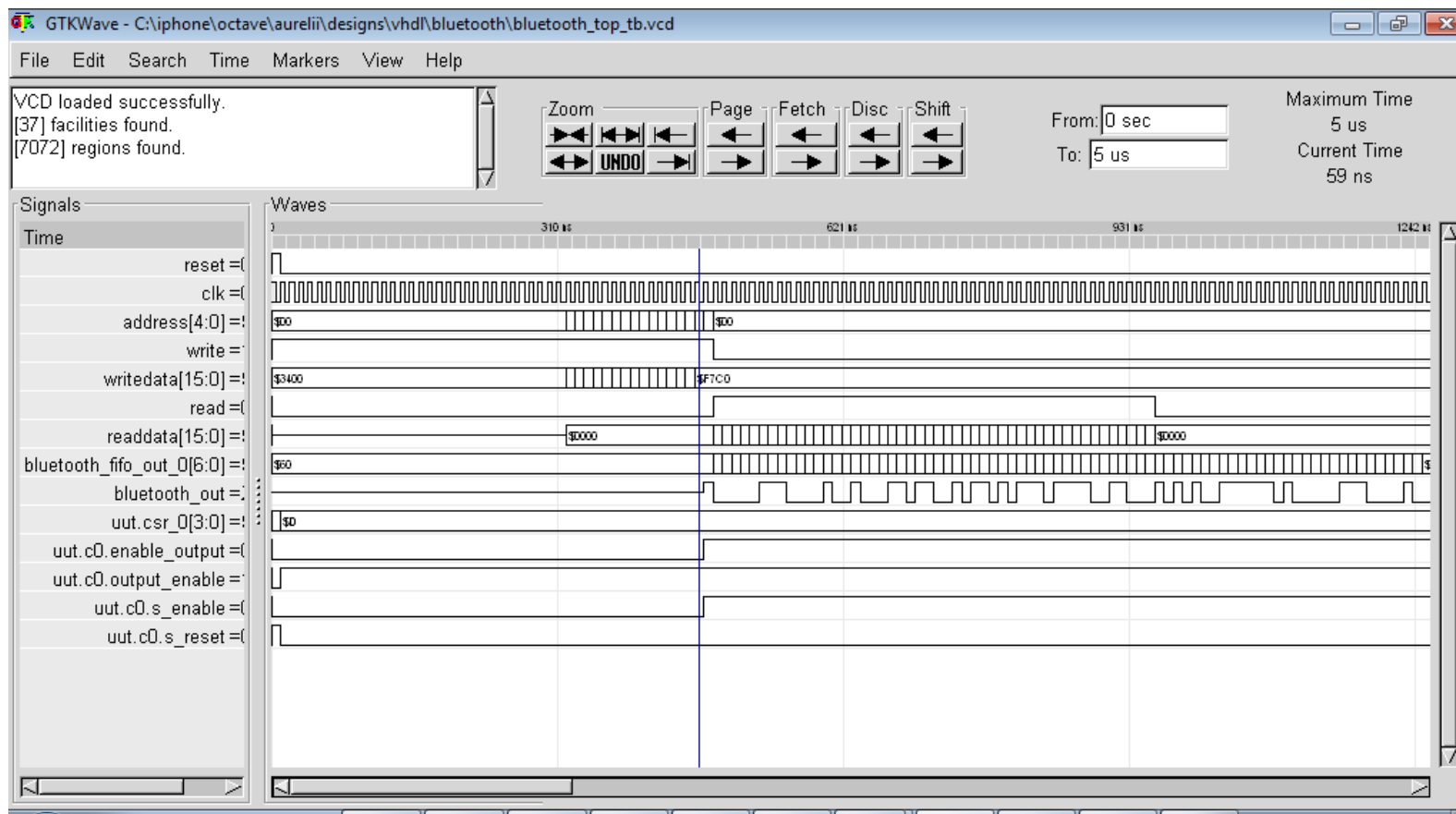

Bluetooth PN Code Peripheral

Product Implementation

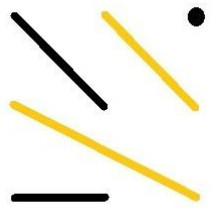

Altera FPGAs

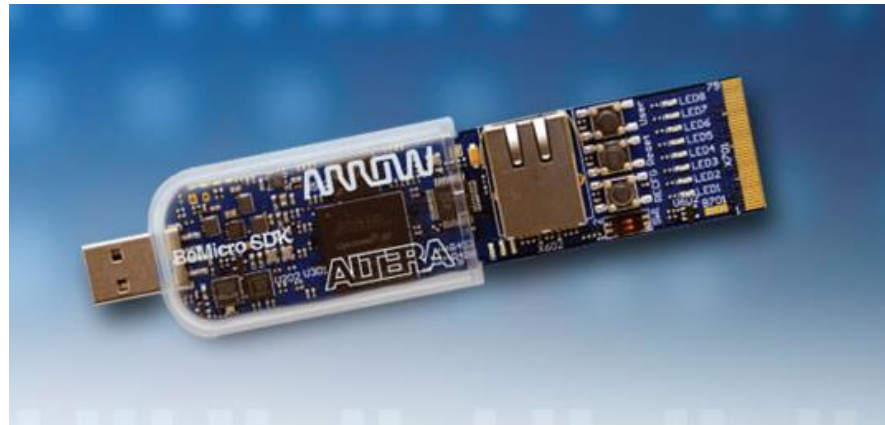

Altera BeMicro Development Kit

Product Implementation

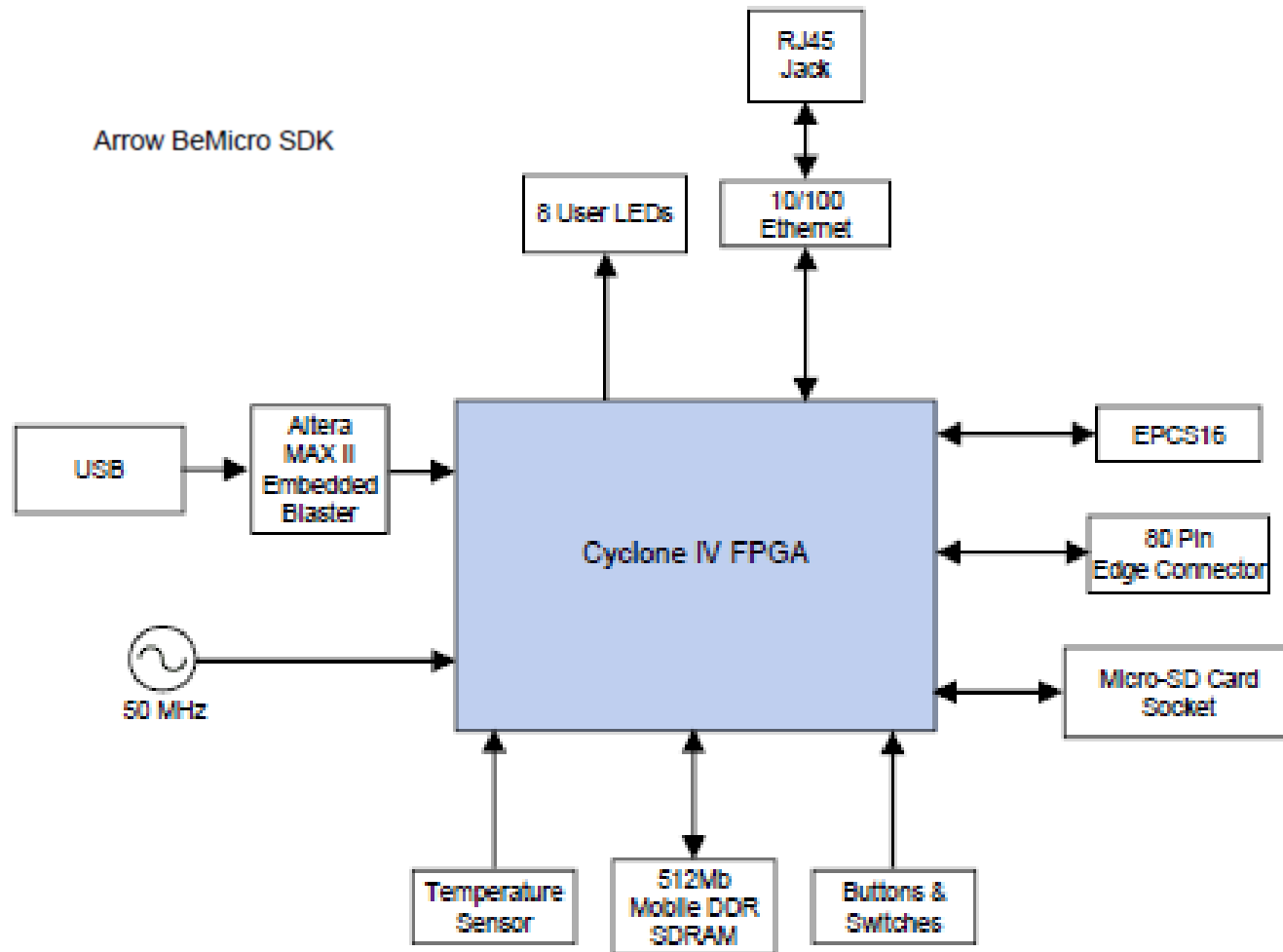
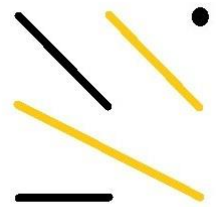

Product Implementation

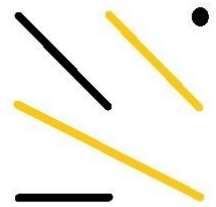

Altera FPGAs

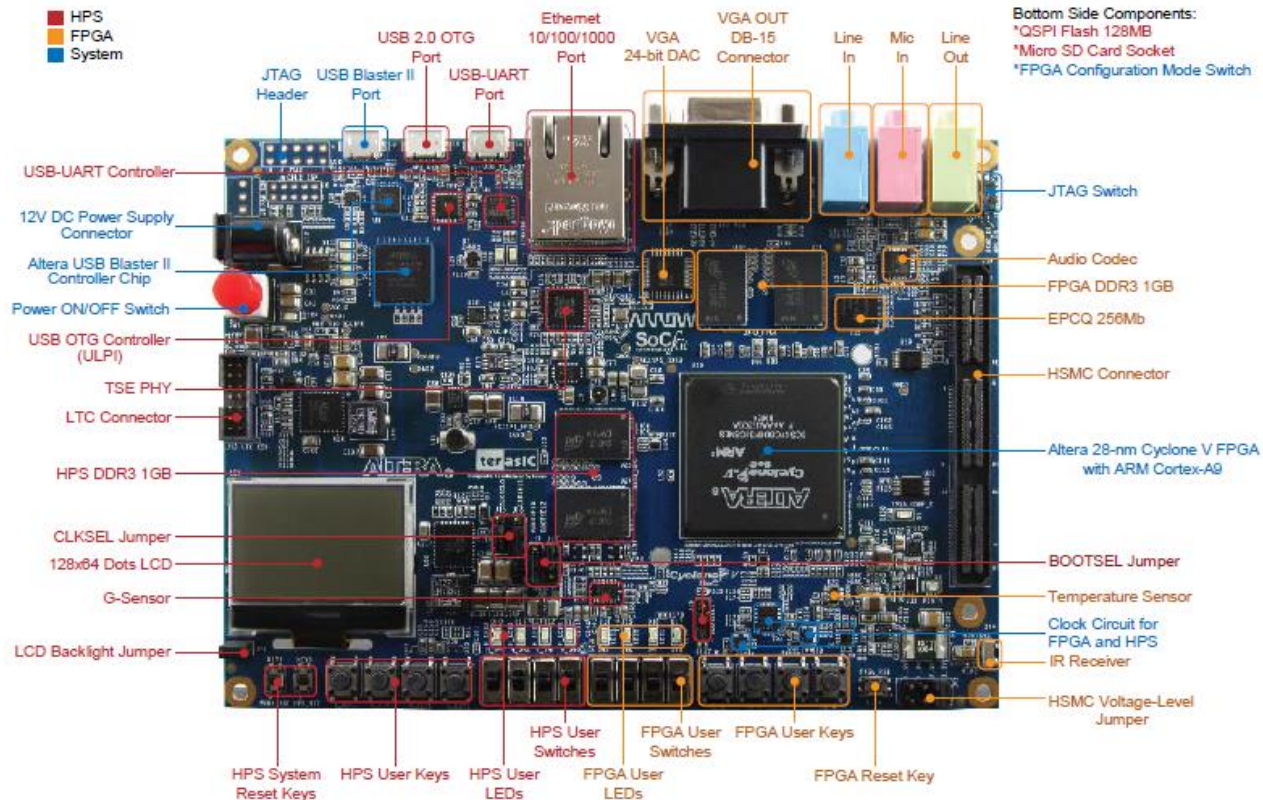
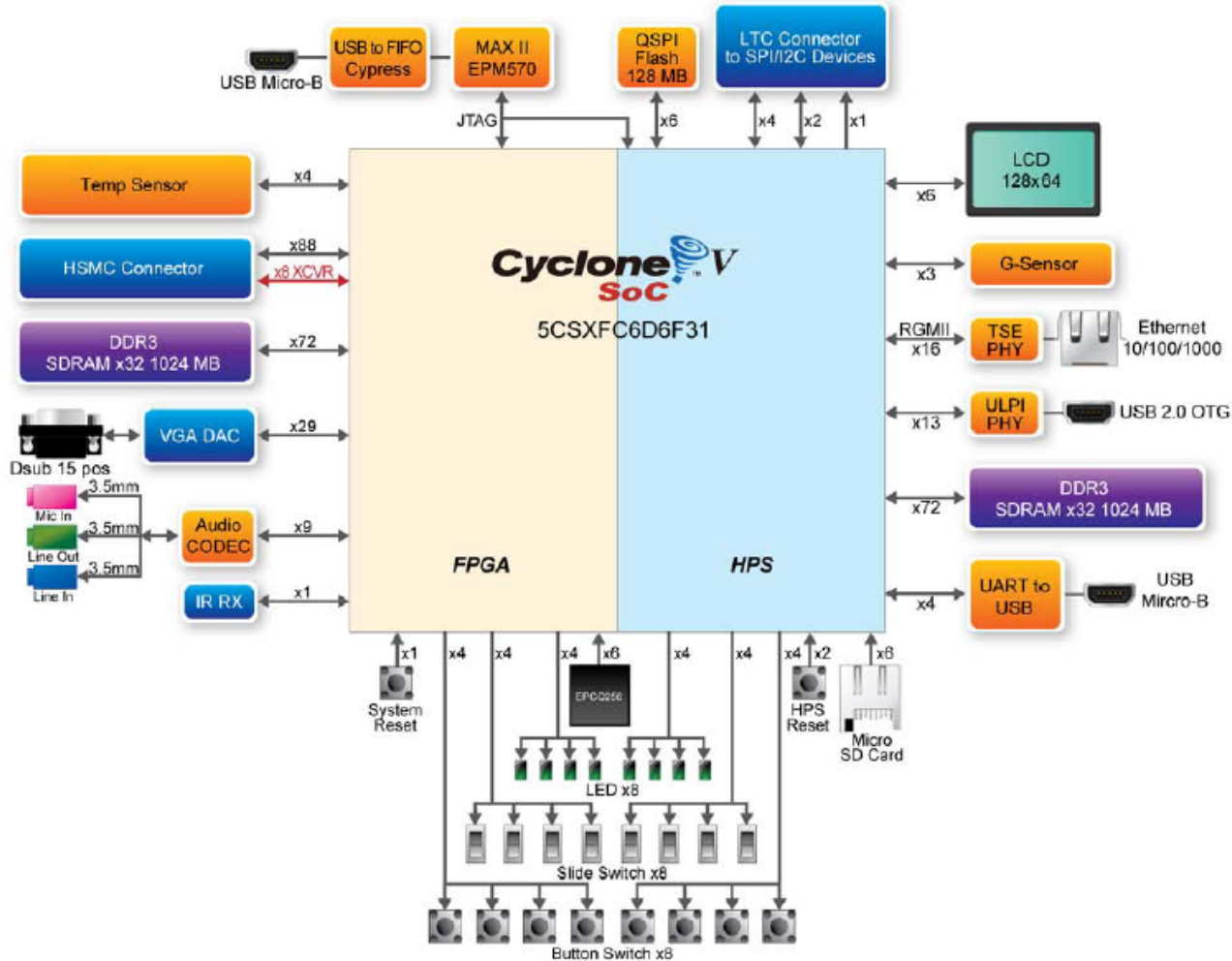
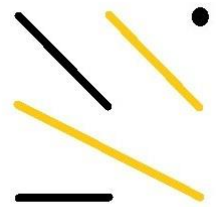

Figure 2-1 Development Board (top view)

Altera SoCKIT Development Kit

Proprietary Confidential

Product Implementation



Altera SoCKIT Development Kit

Product Implementation

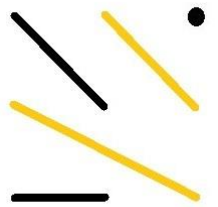

Altera FPGAs



Altera Arria V GX Development Kit

Product Implementation

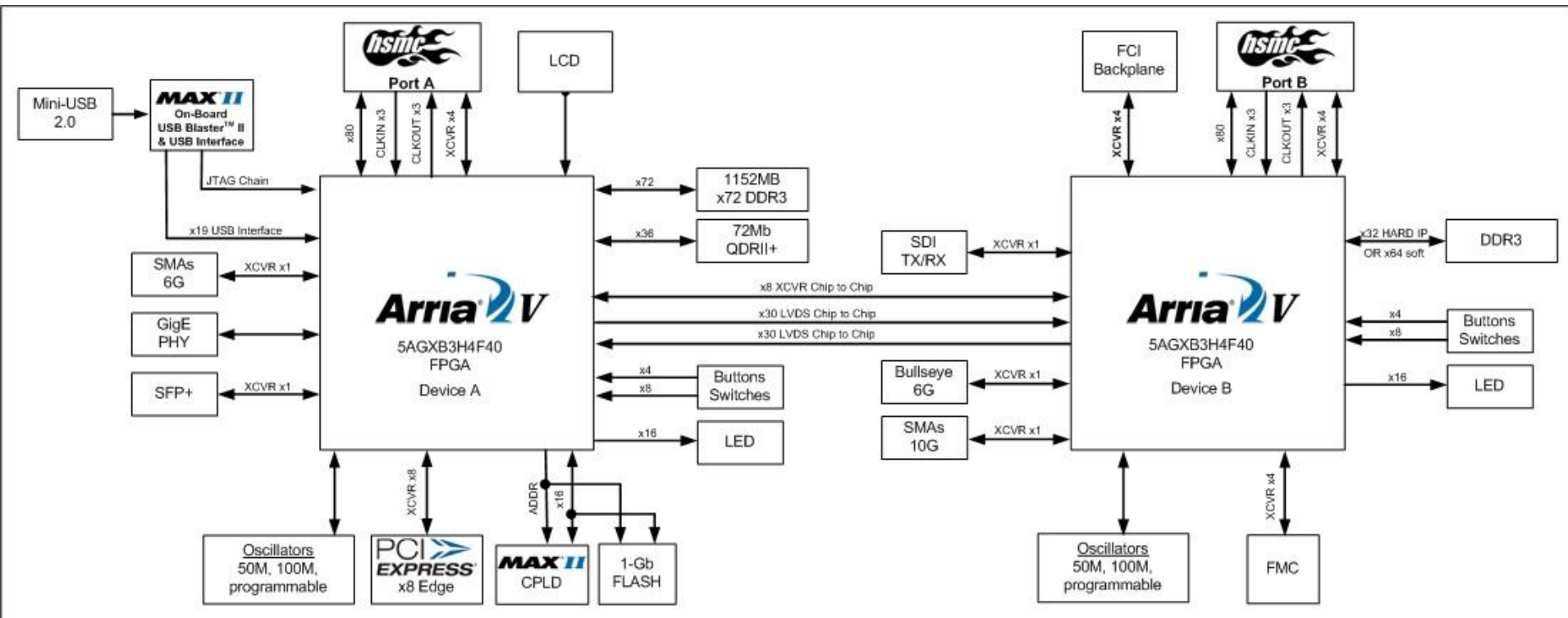
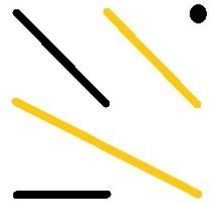

Altera Arria V Development Kit

Aurelii Communications

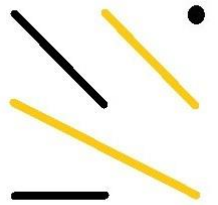

© 2013 Aurelii Communications

www.aureliicomunications.com

info@aureliicomunications.com